



BLENDER TRANSPORTER

Nol-Tec blender transporters are designed to provide trouble-free blending and dense phase pneumatic conveying of most materials.

STANDARD FEATURES:

- Heavy-duty design
- Mill finish interior
- 60° cone
- Rotatable outlet
- Electrical designed to meet customers specifications

OPTIONAL FEATURES:

- Multiple inlets
- Multiple outlets
- Stainless steel construction
- Smart pilot air design
- EXP rated controls

CODES:

- A.S.M.E. Section VIII DIV 1 with National Board registration

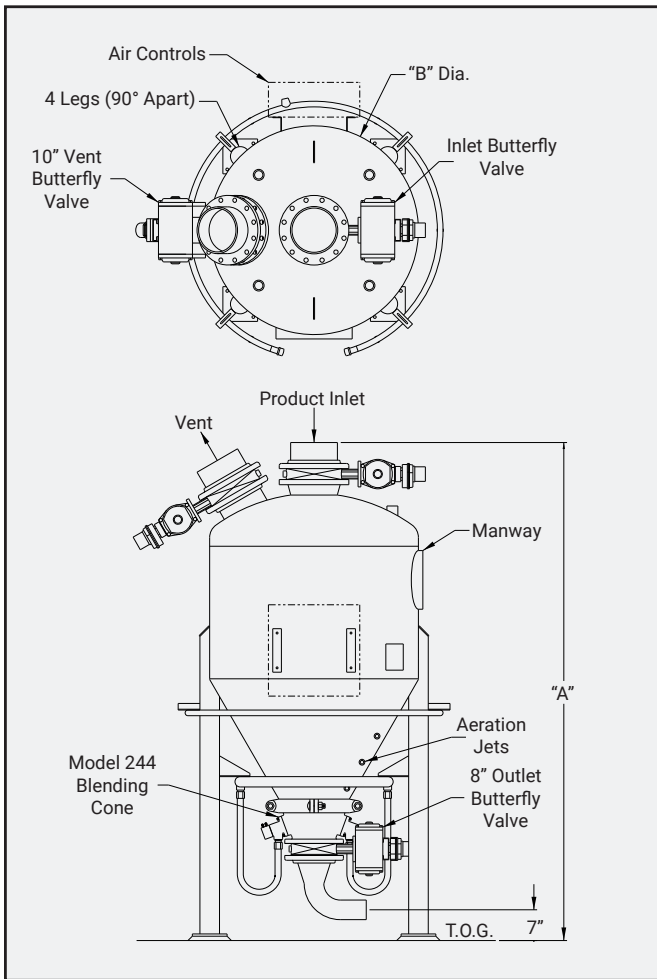

BLENDER TRANSPORTER			
CAPACITY	A	B	SHIP WEIGHT
10 ft ³	7'-6.5"	3'-6"	1,400 lbs
20 ft ³	8'-6.5"	3'-6"	1,550 lbs
30 ft ³	9'-6.5"	4'-0"	1,800 lbs
40 ft ³	11'-0.5"	4'-0"	2,150 lbs
50 ft ³	12'-0.5"	4'-0"	2,400 lbs
60 ft ³	12'-3.5"	4'-6"	2,800 lbs
70 ft ³	13'-3.5"	4'-6"	3,000 lbs
80 ft ³	14'-3.5"	4'-6"	3,250 lbs
90 ft ³	14'-3.5"	5'-0"	3,450 lbs
100 ft ³	14'-9.5"	5'-0"	3,700 lbs

***Larger sizes available**

Specifications subject to change without notice.

TRUSTED TO DELIVER®

Nol-Tec Systems, Inc | 425 Apollo Drive | Lino Lakes, MN 55014
651.780.8600 | sales@nol-tec.com | www.nol-tec.com

5.011.SALE.04.05.24.04

