



TRANSPORTER

Nol-Tec transporters are designed to provide trouble-free dense phase pneumatic conveying of most materials.

STANDARD FEATURES:

- Convey line purge design
- Heavy-duty design
- Mill finish interior
- 60° cone
- Rotatable outlet
- Electrical designed to meet customers specifications

OPTIONAL FEATURES:

- Non-purge design
- Continuous convey system
- Smart pilot air design
- Multiple inlets
- Stainless steel construction
- EXP rated controls

CODES:

- A.S.M.E. Section VIII, DIV 1 with National Board registration

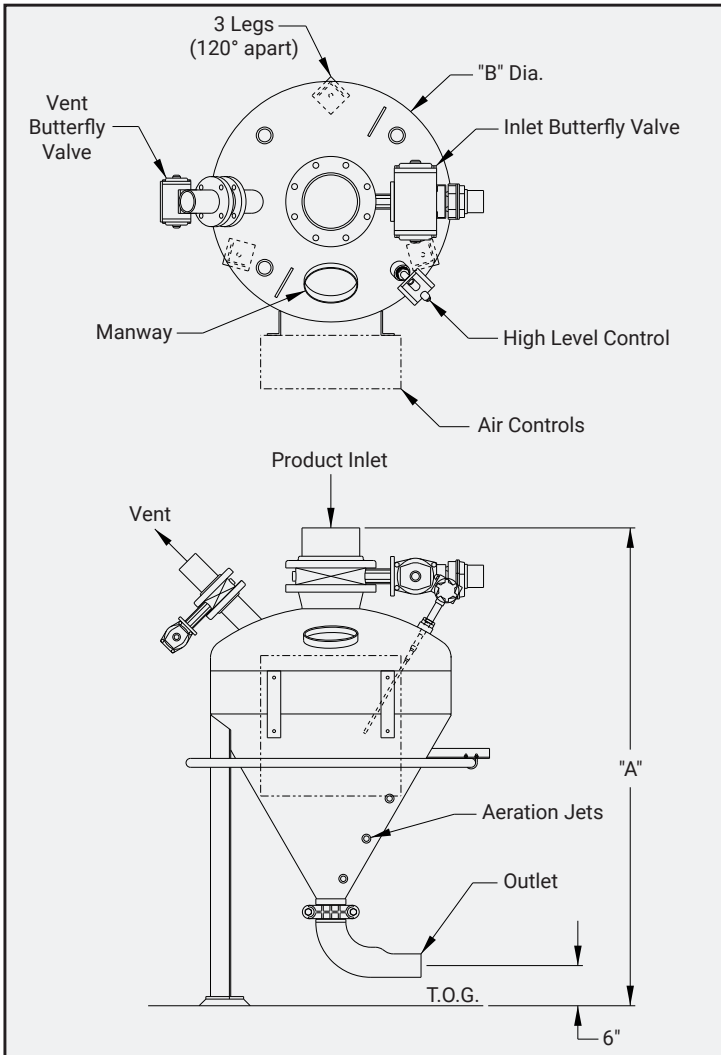

TRANSPORTER

CAPACITY	A	B	SHIP WEIGHT
2.5 ft ³	4'-2.5"	2'-0"	450 lbs
5 ft ³	5'-2.5"	2'-0"	650 lbs
10 ft ³	5'-11.5"	3'-0"	900 lbs
20 ft ³	6'-11.5"	3'-6"	1,220 lbs
30 ft ³	8'-2.5"	3'-6"	1,720 lbs
40 ft ³	9'-2.5"	3'-6"	1,890 lbs
50 ft ³	9'-1.5"	4'-6"	1,935 lbs
60 ft ³	9'-8.5"	4'-6"	2,030 lbs
70 ft ³	10'-5"	4'-6"	2,215 lbs
80 ft ³	11'-0"	4'-6"	2,300 lbs
90 ft ³	11'-8"	4'-6"	2,460 lbs
100 ft ³	12'-3"	4'-6"	2,570 lbs

***Larger sizes available**

Specifications subject to change without notice.

TRUSTED TO DELIVER®

Nol-Tec Systems, Inc | 425 Apollo Drive | Lino Lakes, MN 55014
651.780.8600 | sales@nol-tec.com | www.nol-tec.com

5.006.SALE.04.05.24.04

