



# MANUAL BAG DUMP STATION

*The Nol-Tec manual bag dump is a complete work station equipped with an exhauster fan, cartridge dust collector, and collecting hopper.*

## STANDARD FEATURES:

- Heavy-duty mild steel construction
- Compact design
- Easy filter access
- Heavy-duty filter media
- Manual push button cartridge cleaning utilizing compressed air
- 100% material recovery

## SPECIFICATIONS:

- **Hopper capacity:** 5 ft<sup>3</sup>
- **Filter area:** 180 ft<sup>2</sup>
- **Compressed air:** Clean and dry at 80 PSIG minimum
- **Dust capture velocity:** 200 FPM
- **Exhauster:** 800 CFM; 1.5 HP; T.E.F.C.; 230-460V/3Ph/60Hz

## OPTIONAL FEATURES:

- Hopper aeration
- Stainless steel construction
- Interior coatings and finishes
- Extended work surface
- Various discharge designs
- Easy access lift assisted door
- Door proximity switch
- Bag compactor
- Bag cutter
- Contact Nol-Tec with any special requirements

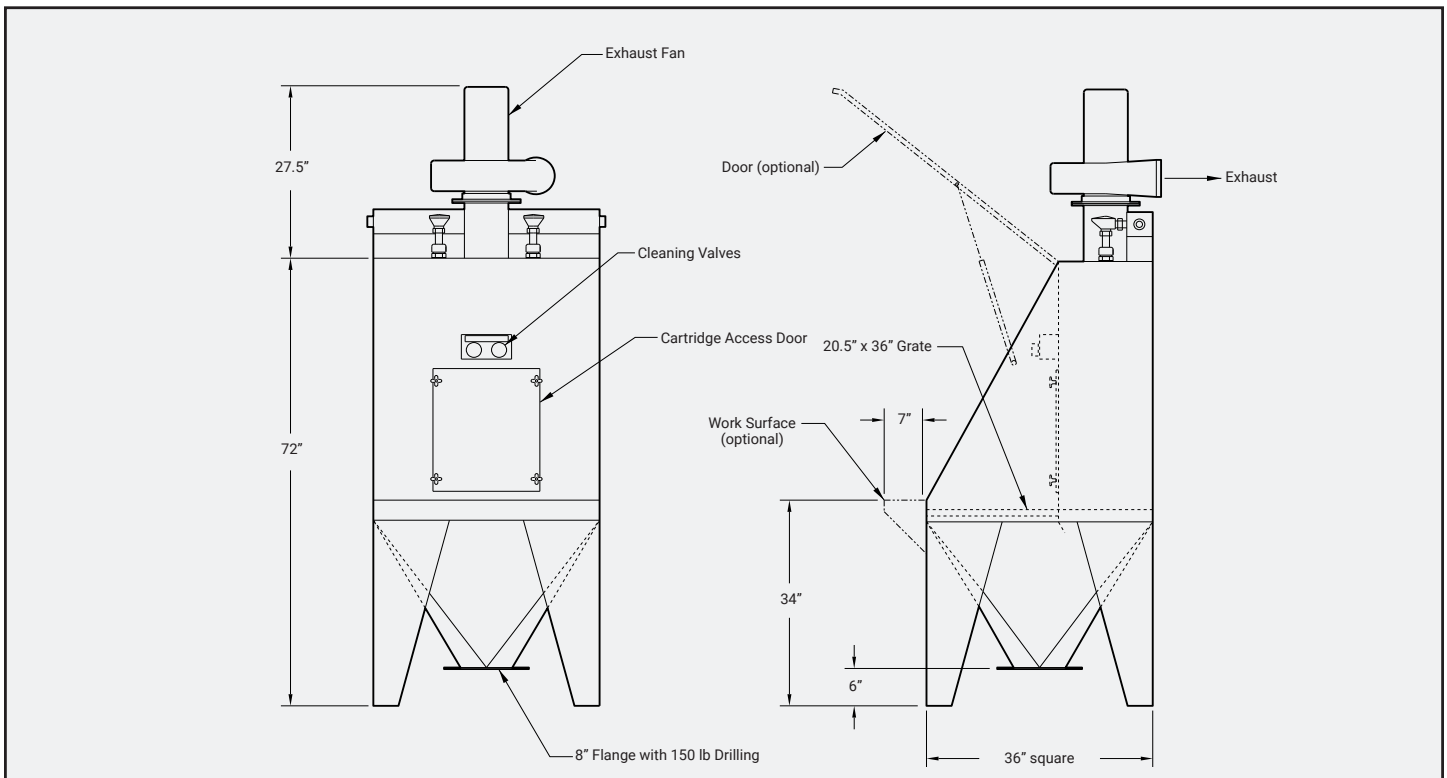

*Specifications subject to change without notice.*

**TRUSTED TO DELIVER®**

Nol-Tec Systems, Inc | 425 Apollo Drive | Lino Lakes, MN 55014  
651.780.8600 | sales@nol-tec.com | www.nol-tec.com

5.020.SALE.02.13.24.05

