



USDA-ACCEPTED AERATOR

The Nol-Tec USDA-Accepted aerator for dry dairy applications effectively aerates or dislodges materials in silos, bins, and chutes.

STANDARD FEATURES:

- Stainless steel valve seat directs air into material at various angles
- Adapter fitting for bin wall designed for cone angle and size
- USDA-3A-compliant o-rings and gaskets
- External replacement of wear parts
- Ferruled valve manifold connection for regulated air
- Ra32 finish (or better) on product contact surfaces

SPECIFICATIONS:

- **Aeration air:** Dry and filtered to USDA standards; 80 PSIG regulated to required pressure
- **Control air:** Clean and dry at 80 PSIG minimum
- **Temperature range:** 200° F maximum
- **Weight:** 15 lbs

OPTIONAL FEATURES:

- Individual solenoid valve for aerator sequencing
- Hazardous location design
- Pneumatic and electrical controls

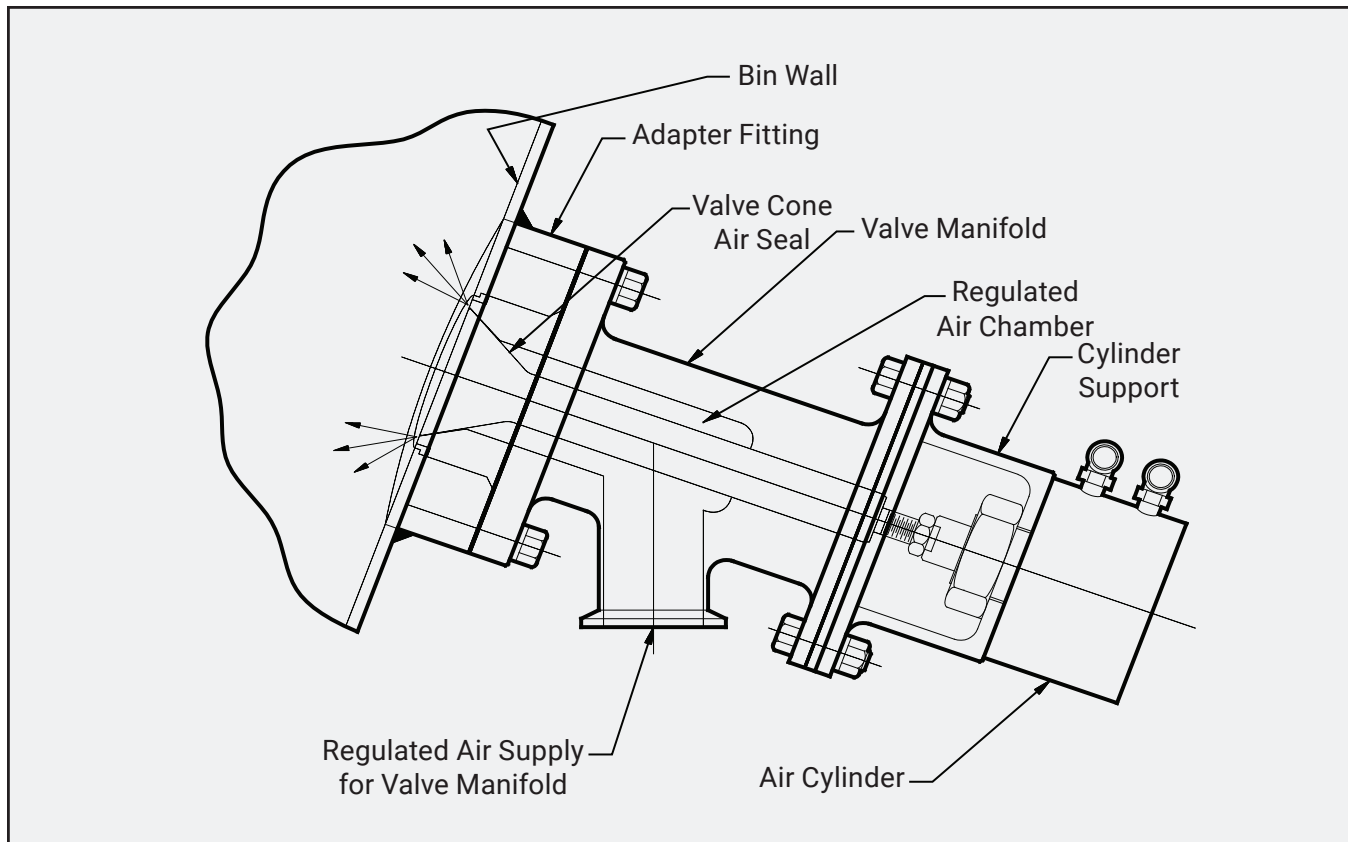

Specifications subject to change without notice.

TRUSTED TO DELIVER®

Nol-Tec Systems, Inc | 425 Apollo Drive | Lino Lakes, MN 55014
651.780.8600 | sales@nol-tec.com | www.nol-tec.com

5.043.SALE.10.23.18.03

