



MANUAL BAG DUMP STATION

The Nol-Tec manual bag dump is a complete work station equipped with an exhauster fan, cartridge dust collector, and collecting hopper.

STANDARD FEATURES:

- Heavy-duty mild steel construction
- Compact design
- Easy filter access
- Heavy-duty filter media
- Manual push button cartridge cleaning utilizing compressed air
- 100% material recovery

SPECIFICATIONS:

- **Hopper capacity:** 5 ft³
- **Filter area:** 180 ft²
- **Compressed air:** Clean and dry at 80 PSIG minimum
- **Dust capture velocity:** 200 FPM
- **Exhauster:** 850 CFM; 1.5 HP; T.E.F.C.; 230-460V/3/60Hz
- **Electrical:** 24 VDC

OPTIONAL FEATURES:

- Hopper aeration
- Stainless steel construction
- Differential pressure gauge
- Interior coatings and finishes
- Extended work surface
- Various discharge designs
- Drum dump hopper
- Easy access lift assisted door
- Differential automatic cleaning
- Door proximity switch
- Pneumatic and electrical controls
- Contact Nol-Tec with any special requirements

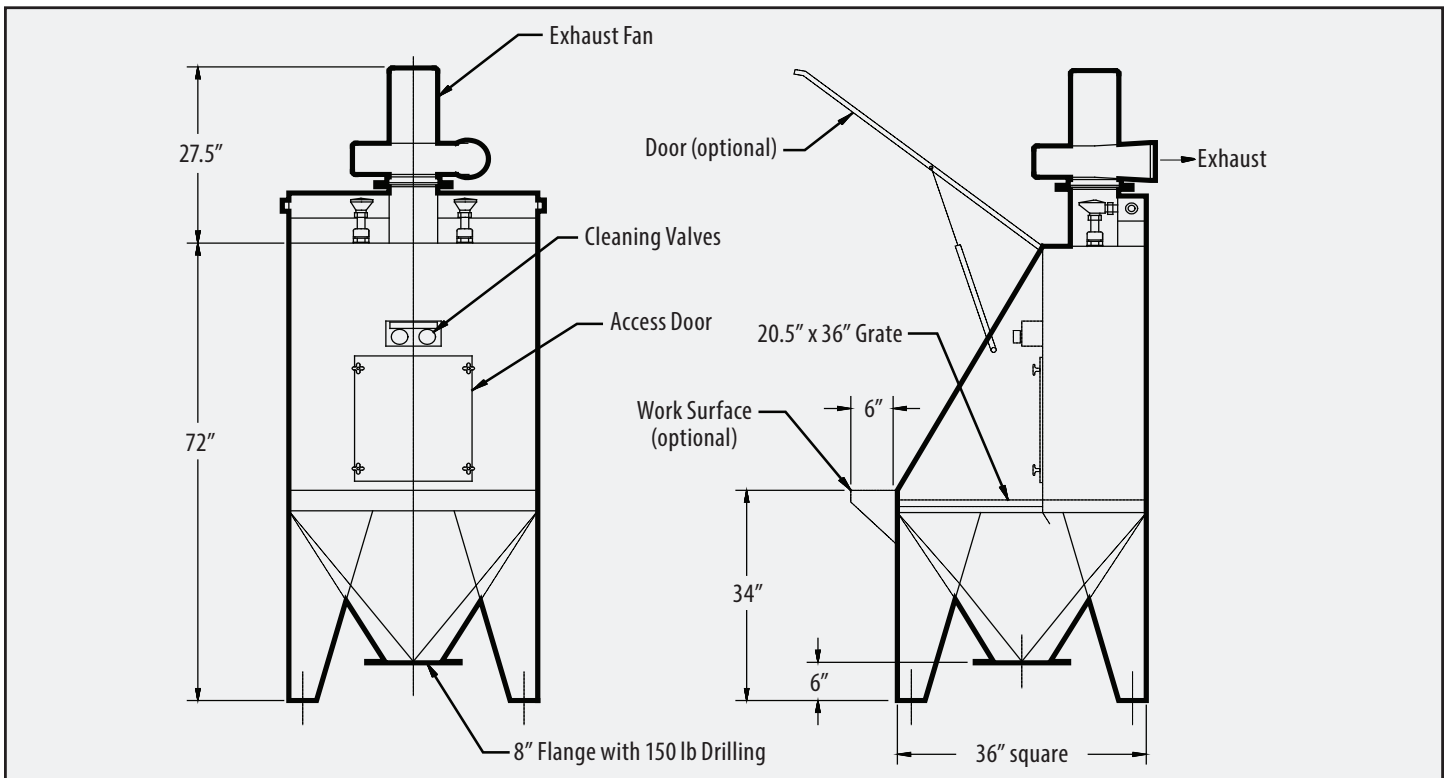

Specifications subject to change without notice.

TRUSTED TO DELIVER®

Nol-Tec Systems, Inc | 425 Apollo Drive | Lino Lakes, MN 55014
651.780.8600 | sales@nol-tec.com | www.nol-tec.com

5.020.SALE.10.23.18.04

