



SIDE ENTRY DUST COLLECTOR

The Nol-Tec side entry dust collector effectively filters dust laden air created by pneumatic conveying systems or other processes.

STANDARD FEATURES:

- Heavy gauge continuous welded construction
- Reinforced housing
- Venturi reverse jet cleaning
- Continuous cleaning design
- Bottom grid
- Cartridge or bag filter media
- Magnehelic gauge
- Bird screen and weatherhood
- Quick-release bag clamps
- Access door
- Designed up to 17" w.g.

SPECIFICATIONS:

- **Compressed air:** Clean and dry at 80 PSIG minimum
- **Electrical:** 24VDC
- **Temperature:** Polyester bags 270° F; Polyester cartridge and urethane ends 225° F

OPTIONAL FEATURES:

- Stainless steel construction
- Hazardous location design
- High-temperature design
- Variety of filter media materials available
- Exhauster
- Hopper bottom
- Additional access doors
- Differential automatic cleaning
- Electrical: 110-120V; 50-60Hz

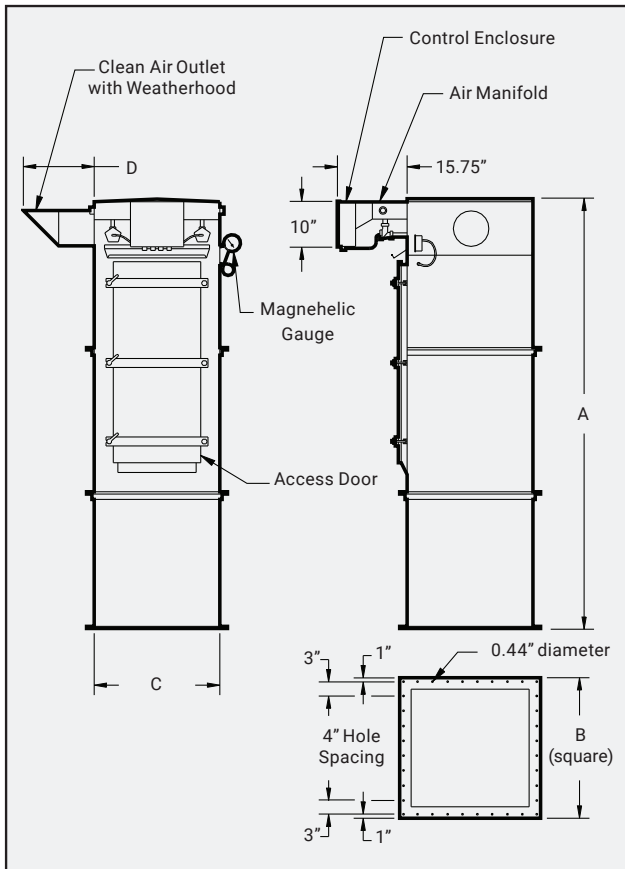

Specifications subject to change without notice

SIDE ENTRY DUST COLLECTOR						
Model	Cartridge Filter Area	Bag Filter Area	A	B	C	D
36-NT-9	180 ft ²	41 ft ²	60.0"	28.0"	24.0"	16.0"
60-NT-9	270 ft ²	68 ft ²	84.0"	28.0"	24.0"	16.0"
84-NT-9	540 ft ²	95 ft ²	108.0"	28.0"	24.0"	16.0"
36-NT-16	320 ft ²	72 ft ²	60.0"	36.0"	32.0"	16.0"
60-NT-16	480 ft ²	120 ft ²	84.0"	36.0"	32.0"	16.0"
84-NT-16	960 ft ²	168 ft ²	108.0"	36.0"	32.0"	16.0"
60-NT-25	750 ft ²	188 ft ²	84.0"	44.0"	40.0"	16.0"
84-NT-25	1,500 ft ²	263 ft ²	108.0"	44.0"	40.0"	16.0"
60-NT-36	1,080 ft ²	270 ft ²	84.0"	52.0"	48.0"	20.0"
84-NT-36	2,160 ft ²	378 ft ²	108.0"	52.0"	48.0"	20.0"
60-NT-49	1,470 ft ²	368 ft ²	84.0"	60.0"	56.0"	20.0"
84-NT-49	2,940 ft ²	515 ft ²	108.0"	60.0"	56.0"	20.0"
60-NT-64	1,920 ft ²	480 ft ²	84.0"	68.0"	64.0"	20.0"
84-NT-64	3,840 ft ²	672 ft ²	108.0"	68.0"	64.0"	20.0"
60-NT-81	2,430 ft ²	608 ft ²	84.0"	76.0"	72.0"	20.0"
84-NT-81	4,860 ft ²	851 ft ²	108.0"	76.0"	72.0"	20.0"
60-NT-100	3,000 ft ²	750 ft ²	84.0"	84.0"	80.0"	20.0"
84-NT-100	6,000 ft ²	1,050 ft ²	108.0"	84.0"	80.0"	20.0"

*Larger size models available upon request

TRUSTED TO DELIVER®

Nol-Tec Systems, Inc | 425 Apollo Drive | Lino Lakes, MN 55014
651.780.8600 | sales@nol-tec.com | www.nol-tec.com

5.014.SALE.10.23.18.04

