



END AND SILO RECEIVERS

Nol-Tec's receivers provide long-lasting performance for termination of pneumatic conveying systems.

STANDARD FEATURES:

- Heavy-duty plate design
- Continuous welded construction
- Promotes separation of material and conveying air
- Long-lasting

OPTIONAL FEATURES:

- Stainless steel construction
- Various pipe schedules
- Grooved or flanged pipe ends
- Rubber coated contact surface
- Mounting flange
- Silo center fill
- Replaceable internal baffle
- Abrasion resistant plate design

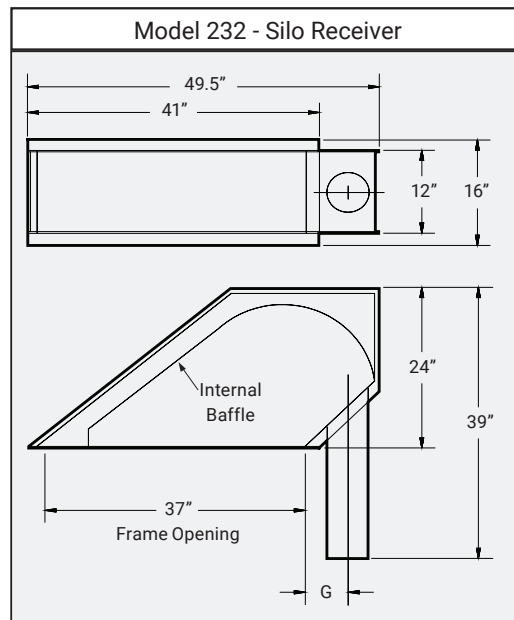
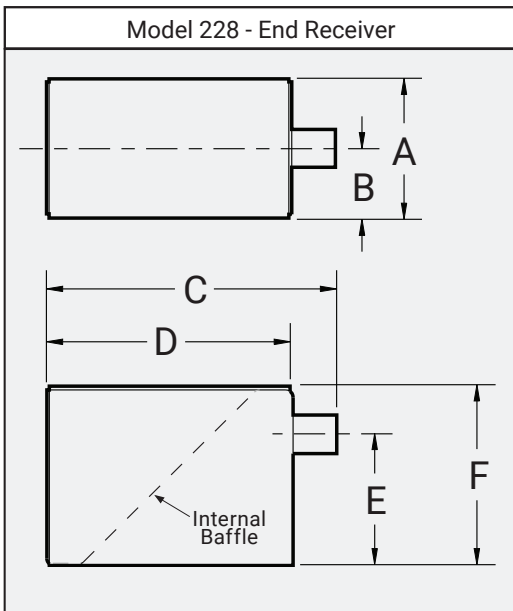

SILO AND END RECEIVER								
PIPE SIZE	A	B	C	D	E	F	G	Ship Weight
2"	6.38	3.19	26.50	23.38	14.00	18.25	--	90 lbs
3"	12.50	6.25	26.50	23.38	14.00	18.25	7.69	150 lbs
4"	12.50	6.25	26.50	23.38	14.00	18.25	7.18	155 lbs
5"	12.50	6.25	26.50	23.38	14.00	18.25	6.69	160 lbs
6"	12.50	6.25	26.50	23.38	14.00	18.25	6.12	165 lbs
8"	18.75	9.38	42.75	36.75	15.00	22.5	--	325 lbs
10"	18.75	9.38	42.75	36.75	15.00	22.50	--	350 lbs

Specifications subject to change without notice.

TRUSTED TO DELIVER®

Nol-Tec Systems, Inc | 425 Apollo Drive | Lino Lakes, MN 55014
651.780.8600 | sales@nol-tec.com | www.nol-tec.com

5.013.SALE.10.23.18.03

