



TRANSPORTER 60° CONE

Nol-Tec transporters are designed to provide trouble-free dense phase pneumatic conveying of most materials.

STANDARD FEATURES:

- Heavy-duty design
- Mill finish interior
- 60° cone
- Manway
- Butterfly valve with pneumatic actuator
- Rotatable outlet

SPECIFICATIONS:

- **Design pressure:** 90 PSIG
- **Temperature range:** -20° F to +450° F
- **Electrical:** 24 VDC

OPTIONAL FEATURES:

- Aeration jets
- Interior coatings and finishes
- Multiple inlets
- Stainless steel construction
- Electrical: 110-120V; 50-60 Hz

CODES:

- A.S.M.E. Section VIII, DIVI with National Board registration

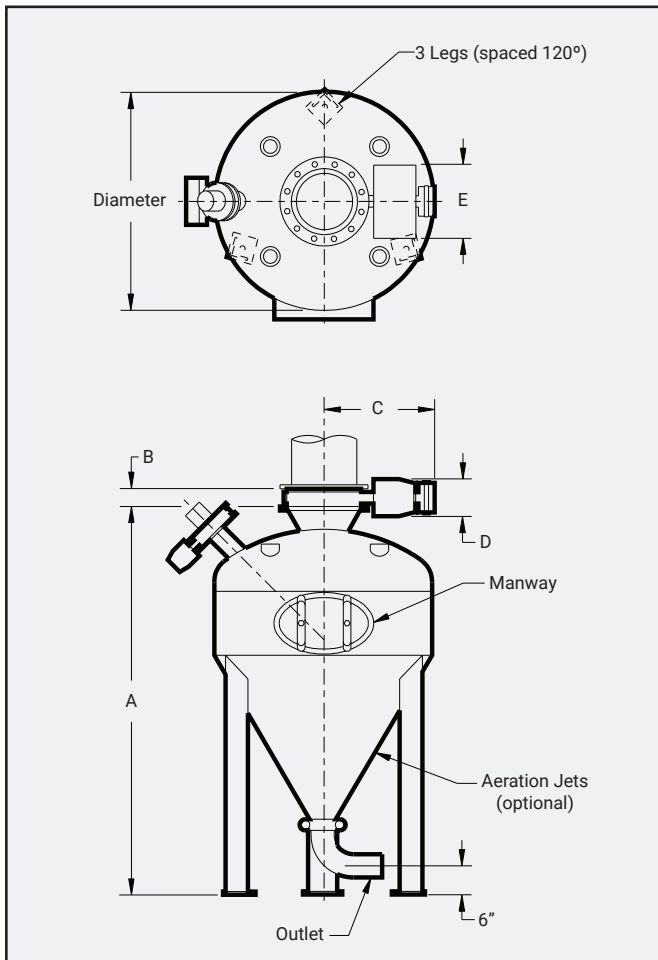

TRANSPORTER

MODEL	CAPACITY	A	DIAMETER	SHIP WEIGHT
201-701	1 ft ³	2'-9"	1'-4"	300 lbs
201-703	2.5 ft ³	3'-5"	2'	450 lbs
201-705	5 ft ³	4'-5"	2'	650 lbs
201-710	10 ft ³	5'-2"	3'	900 lbs
201-720	20 ft ³	6'-2"	3'-6"	1,220 lbs
201-730	30 ft ³	7'-5"	3'-6"	1,720 lbs
201-740	40 ft ³	8'-5"	3'-6"	1,890 lbs
201-750	50 ft ³	8'-4"	4'-6"	1,935 lbs
201-760	60 ft ³	8'-9"	4'-6"	2,030 lbs
201-770	70 ft ³	9'-7"	4'-6"	2,215 lbs
201-780	80 ft ³	10'-2"	4'-6"	2,300 lbs
201-790	90 ft ³	10'-10"	4'-6"	2,460 lbs
201-800	100 ft ³	11'-5"	4'-6"	2,570 lbs
201-7150	150 ft ³	11'	6'	3,360 lbs
201-7200	200 ft ³	12'-9"	6'	3,860 lbs
201-7250	250 ft ³	14'-9"	6'	4,360 lbs
201-7500	500 ft ³	17'	8'	8,000 lbs
201-7750	750 ft ³	18'	10'	10,000 lbs

INLET VALVE

SIZE	B	C	D	E	SHIP WEIGHT
6"	2.12"	20.5"	4.7"	12"	40 lbs
8"	2.5"	20.5"	6"	10.88"	60 lbs
10"	2.5"	21.25"	6"	10.88"	75 lbs
12"	3"	23.75"	8"	15.75"	150 lbs
14"	3"	31"	9"	19"	250 lbs
16"	4"	26.63"	8"	22"	300 lbs
18"	4.25"	28.25"	8"	22"	335 lbs

Specifications subject to change without notice.

TRUSTED TO DELIVER®

Nol-Tec Systems, Inc | 425 Apollo Drive | Lino Lakes, MN 55014
651.780.8600 | sales@nol-tec.com | www.nol-tec.com

5.006.SALE.10.23.18.03

