



# Models 275, 279 & 317 SINGLE BAG/CARTRIDGE DUST FILTERS

*NOL-TEC single bag/cartridge dust filters effectively filter dust laden air created by hopper filling applications.*

**STANDARD FEATURES:**

- Venturi reverse jet cleaning
- Quick access
- Top filter element removal (Model 279)
- Bottom filter element removal (Model 317)
- 100% material recovery

**OPTIONAL FEATURES:**

- Stainless steel construction
- Epoxy coatings
- Variety of filter materials
- Variety of mounting arrangements
- Variety of discharge arrangements

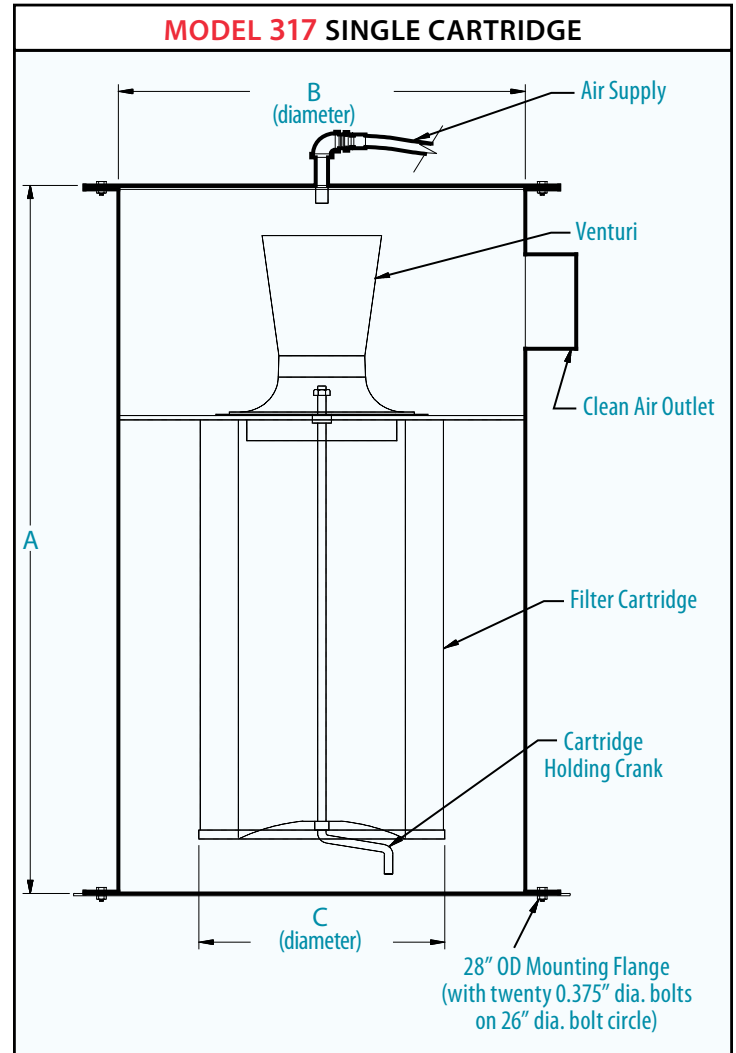
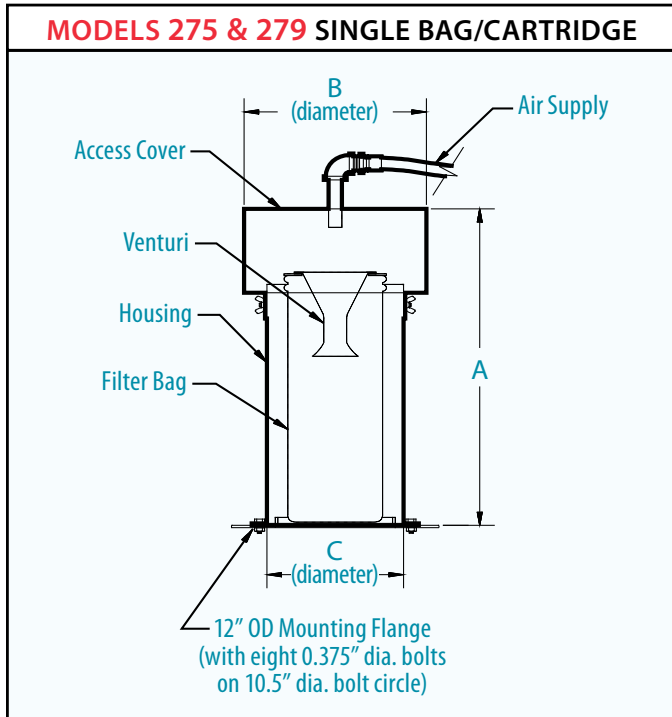

SINGLE BAG/CARTRIDGE DUST FILTERS					
MODEL	TYPE	FILTER AREA	A	B	C
279-225	Bag	2.25 ft <sup>2</sup>	25"	12"	9"
279-450	Bag	4.5 ft <sup>2</sup>	43"	12"	9"
279-3000	Cartridge	30 ft <sup>2</sup>	43"	12"	9"
275-5000	Cartridge	50 ft <sup>2</sup>	27.5"	17"	14"
317-9000	Cartridge	90 ft <sup>2</sup>	33"	24"	12.75"

*Specifications subject to change without notice.*

**Nol-Tec Systems, Inc.**

425 Apollo Drive

Lino Lakes, MN 55014

(651) 780-8600 • (651) 780-4400 fax

sales@nol-tec.com • www.nol-tec.com