



Model 201

TRANSPORTER - 60° CONE

NOL-TEC transporters are designed to provide trouble-free dense phase pneumatic conveying of most materials.

STANDARD FEATURES:

- Heavy-duty design
- Smooth interior
- 60° cone
- Manway
- Erosion allowances on wear surfaces
- Butterfly valve with pneumatic actuator
- Rotatable outlet

SPECIFICATIONS:

- **Design pressure:** 90 PSIG
- **Temperature range:** -20° F to +650° F

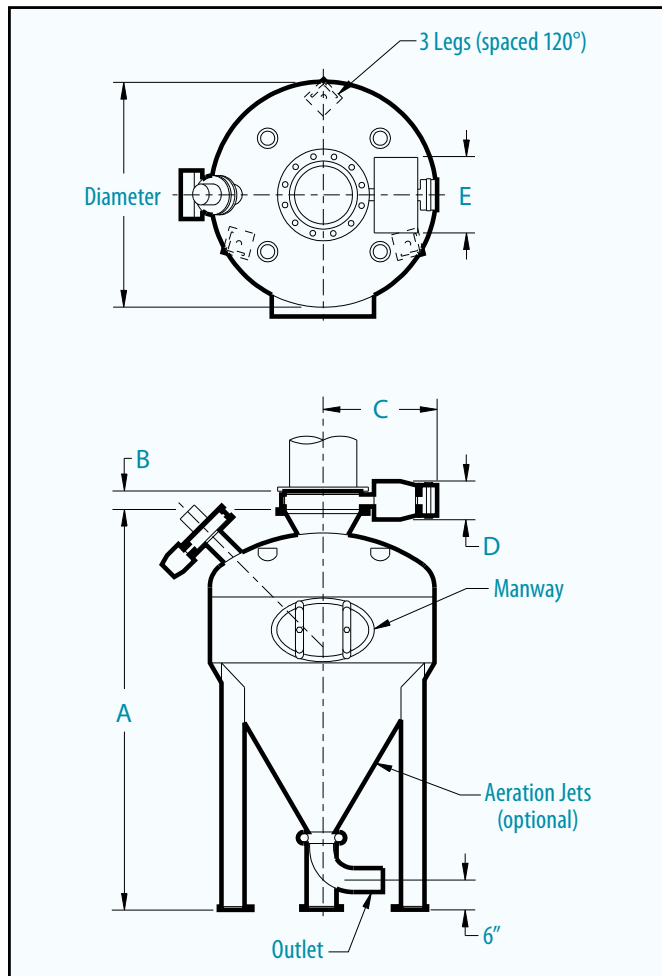

OPTIONAL FEATURES:

- Aeration jets
- Interior coatings
- Multiple inlets
- Stainless steel construction
- Higher pressure and temperature ratings

CODES:

- A.S.M.E. Section VIII with National Board registration

TRANSPORTER				
MODEL	CAPACITY	A	DIAMETER	SHIP WEIGHT
16-60-00.5	0.5 ft ³	2' 6"	1' 4"	145 lbs
16-60-001	1 ft ³	2' 10"	1' 4"	160 lbs
24-60-02.5	2.5 ft ³	3' 6"	2'	270 lbs
24-60-005	5 ft ³	4' 6"	2'	295 lbs
36-60-010	10 ft ³	5' 3"	3'	880 lbs
36-60-015	15 ft ³	6'	3'	1,000 lbs
42-60-020	20 ft ³	6' 3"	3' 6"	1,100 lbs
42-60-030	30 ft ³	7' 6"	3' 6"	1,250 lbs
42-60-040	40 ft ³	8' 6"	3' 6"	1,400 lbs
54-60-060	60 ft ³	9'	4' 6"	1,975 lbs
54-60-080	80 ft ³	10' 3"	4' 6"	2,275 lbs
54-60-100	100 ft ³	11' 6"	4' 6"	2,575 lbs
72-60-150	150 ft ³	12' 3"	6'	3,450 lbs
72-60-200	200 ft ³	14'	6'	4,200 lbs
72-60-250	250 ft ³	15' 9"	6'	4,975 lbs
96-60-500	500 ft ³	18' 9"	8'	8,750 lbs
120-60-750	750 ft ³	20' 3"	10'	10,000 lbs
120-60-1000	1,000 ft ³	23' 6"	10'	11,500 lbs

INLET VALVE					
SIZE	B	C	D	E	SHIP WEIGHT
6"	2.12"	20.5"	5"	12"	50 lbs
8"	2.5"	20.5"	6"	10.88"	60 lbs
10"	2.5"	21.25"	6"	10.88"	75 lbs
12"	3"	23.75"	8"	15.75"	150 lbs
16"	4"	26.63"	8"	20"	300 lbs
18"	4.25"	28.25"	8"	20"	335 lbs
20"	6"	29.63"	8"	20"	425 lbs

Specifications subject to change without notice.

Nol-Tec Systems, Inc.

425 Apollo Drive

Lino Lakes, MN 55014

(651) 780-8600 • (651) 780-4400 fax

sales@nol-tec.com • www.nol-tec.com